

User manual

Power quality analyser and smart meter

ARTIQ 244

Document revision	Release date	Valid for versions			
		Hardware	Bootloader	Firmware	Software ENVIS
1.6	10.6.2026	2.0	4.4	5.0	2.2
1.5	21.8.2025	2.0	4.4	5.0	2.2
1.4	11.7.2025	2.0	4.4	5.0	2.2
1.3	16.4.2024	2.0	4.4	5.0	2.2
1.2	11.4.2024	2.0	4.4	4.11	2.2
1.1	13.3.2024	2.0	4.4	4.11	2.2

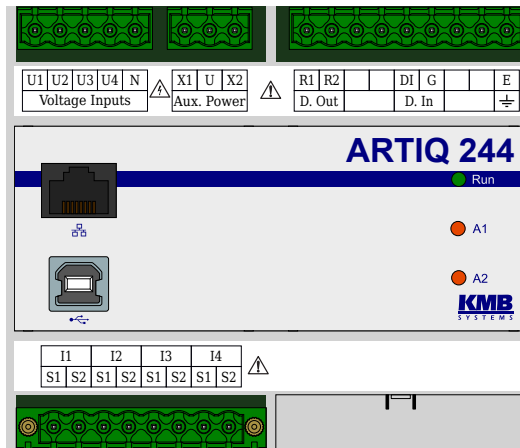

Figure 1: ARTIQ 244 U 100 X/1A E

Contents

- 1 Basic description 3**
 - 1.1 Types and options 3
 - 1.2 News in version 4.0 3
 - 1.3 Accessories 4
 - 1.4 Measuring principles and signal processing 4

- 2 Operating the measuring instrument 6**
 - 2.1 Safety requirements for use of the ARTIQ 244 6
 - 2.2 Warning 6
 - 2.3 The meaning of the symbols used on the device 7
 - 2.4 Installing the device in a switchboard 7
 - 2.4.1 Auxiliary voltage 7
 - 2.4.2 Measured voltages 9
 - 2.4.3 Measured currents 9
 - 2.4.4 Connection of communication channels 10
 - 2.4.5 Digital output 10
 - 2.4.6 Digital input 10
 - 2.5 Description of LED indicators 10

- 3 Technical parameters 11**
 - 3.1 Basic parameters 11
 - 3.2 Measured quantities 13
 - 3.3 Inputs and outputs 15
 - 3.4 Power quality and energy management 16

- 4 Maintenance, service and warranty 19**

ARTIQ 244 U 100 X/1A E	
Instrument Model	ARTIQ 244 = class A power quality analyzer, 4U, 4I, 1R
Auxiliary Power Supply	U = 75 V ÷ 275 V AC, 75 V ÷ 350 V DC
Nominal Measuring Voltage	100 = 57,7 V AC (L-N) / 100 V AC (L-L)
Current Inputs	X/1A = input for 1A AC MTP (indirect measurement)
Communication Interface	E = Ethernet, USB

Figure 2: Ordering codes and schemas.

1 Basic description

ARTIQ 244 is designed to remotely monitor power consumption and voltage quality. It is designed for installation on a din rail or mounting panel and does not have a local display in the basic version. This concept is suitable for a wide range of applications in power engineering and smart networks, in building automation and individual production processes, for remote infrastructure supervision and also for automatic load management. The device is not equipped with local controls and therefore cannot easily interfere with the functions it performs - in simple terms, it should not attract the special attention of people in easily accessible installations. To protect settings and collected data, the device can be locked with a pin or password.

It uses the Ethernet communication line for connection to a remote control systems. The USB is designated for local configuration and occasional downloads. The instrument measures four voltages and four currents. It has one digital input and one relay output.

1.1 Types and options

The ARTIQ 244 is available in various configurations according to the customer's specifications¹. On figure 2 marking schema of all available options is drawn.

1.2 News in version 4.0

- Four-quadrant measurement of active and reactive energy
- Modbus register extension (power quality, voltage events, FW update, FW module activation, archive download)
- Extension of device status information (CRC of settings, GUID, ...)
- Calculation of supraharmonic up to 9 kHz
- Detailed display of the device type on the website
- Improved handling of DC signals in the general oscillogram
- Implementation of event timestamps with nanosecond resolution
- Possibility to set the averaging interval to less than 1 s
- The device and all its data can be uniquely identified with the help of a newly implemented identifier (GUID)
- MQTT implementation (in beta testing)
- Selected information about the status of the device on the website
- Communication encryption implementation (AES, HMAC)

¹A complete and up-to-date list of optional accessories can be obtained from your dealer upon request.

Table 1: Standard and optional accessories

Ordering code	Accessory		Description
	Standard	Number of pcs.	
691 351 500 003	☑	1	Power connector
691 351 500 005	☑	1	Voltage connector
691 351 500 009	☑	1	I/O and earth connector
691 340 500 008	☑	1	Current connector
BC 53,6 BS U11 KMGY	☑	1	Cover for enclosure
726 141 001	☑	1	Cover for USB
726 154 101	☑	1	Cover for Ethernet
USB 2.0 A-B, 2 m	☒		USB cable

1.3 Accessories

In table 1 is a list of accessories that are automatically delivered to each ARTIQ 244 and accessories that can be specified when ordering or additionally purchased.

1.4 Measuring principles and signal processing

Connection and measurement

- AC supply voltage $100 \div 240$ V
- four voltage inputs (U_1, U_2, U_3, U_4) for direct or indirect measurement of star or delta voltage, single-phase and Aron
 - nominal voltage 57,7/100 V
 - measurement category III/300V
- four current inputs (I_1, I_2, I_3, I_4) for indirect measurement
 - standard variant X/1 A — inputs for measurement with common current transformers with rated current of secondary winding 1 A
 - measurement category is determined by the CTs used, inputs of the device itself are isolated for measurement category III/150 V
- 28.8 kHz sampling, continuous measurement of voltage and current inputs
- calculate 128 components of harmonic voltages and currents
- evaluation of all commonly measured single- and three-phase quantities such as power (active, reactive, apparent, deformation and fundamental active and reactive power), power factors, harmonics and THD for voltages and currents, ...
- digital input for GPS time synchronization
- relay digital output

Measured data recording

- built-in precise real time circuit with backup battery
- memory for recording measured data and events with a capacity of 512MB
- individual archives can get dynamically allocated storage capacity
- aggregation interval from 200ms to 24hours

Data transmission and evaluation

- ENVIS 2.0 or higher is available for free download
- system service ENVIS.Online for downloading and processing of archived measurement data
- tools for downloading, exporting and processing data using custom scripts or via command line
- data library for developing custom applications in C # / . NET or for Linux (C / C ++, .NET Core)
- for data transfer, instrument setting and firmware update, the Ethernet and USB communication interfaces are used

Supported firmware modules

- Power Quality (PQ) - Extends analyzer features with new quantities (inter-harmonic, flicker, selective voltmeter/RCS). It also adds the EN 50160 power quality archive and voltage event archive. Thus, with activation of the PQ module the ARTIQ 244 becomes a full-fledged Class A power quality analyzer..
- General Oscillograms (GO) - Adds the ability to record transients in form of raw samples of measured voltage and current signals.
- Ripple Control Signals (RCS) - Allows you to record telegrams of remote remote control (RCS) and their voltage levels.
- UDP Push (UP) — allows reading of archived data by Modbus TCP or RTU protocol and also active upload (push) of data via Ethernet by UDP protocol to a dedicated server (does not require control of communication from the server side).

A detailed list of the technical parameters of the device is given in the chapter 3.

2 Operating the measuring instrument

2.1 Safety requirements for use of the ARTIQ 244



When working with the device, all necessary precautions must be taken to protect persons and property against injury and electric shock.

- Danger of electric shock! Do not open the device!
- The device must be operated by a person with the required qualifications for such operation and this person must be familiar with the principles of working with the device described in this description.
- Follow the user manual and keep it with the device.
- Only connect the device as described in the instructions and in a de-energized state.
- Do not use the device in an explosive atmosphere.
- Make sure that the device is not operated outside the limits. See technical parameters.
- The device is cleaned when switched off with a dry cloth or brush.
- If the unit is connected to parts that are under dangerous voltage, all necessary precautions should be taken to protect users and equipment from electric shock.
- The operator performing installation or maintenance of the equipment must be equipped with personal protective equipment and other safety equipment at work.
- If the analyzer is used in a manner not specified by the manufacturer, the protection provided by the analyzer may be reduced.
- If the analyzer or its accessories appear to be damaged or not working properly, do not use it and send it for repair.
- Repairs to the device may only be carried out by the manufacturer or a service organization authorized by him.

2.2 Warning

This device is Group 1 and Class A according to EN 55011 (CISPR 11).

Group 1 The device generates and/or uses radio frequency energy which is necessary for the internal function of the device itself.









Class A The device is suitable for use in all environments other than domestic and those directly connected to the low voltage public electricity network that supplies buildings used for domestic purposes. There may be potential difficulties in ensuring electromagnetic compatibility in other environments due to conducted and radiated disturbances.



This device is not intended for use in residential environments and may not provide adequate protection to radio reception in such environments (EN 55011, Section 5).

2.3 The meaning of the symbols used on the device

Table 2: Symbols

Symbol	Description
	Warning
	Warning, possibility of electric shock
	Alternating current
	Direct current
	CE mark declaring conformity with European regulations and regulations
	The device must not be disposed of with household waste
	Equipment with double or reinforced insulation
	USB communication interface

2.4 Installing the device in a switchboard

The ARTIQ 244 is designed for mounting on a DIN rail. In the figure 3, the dimensions of the device are drawn. The hole positions for the wall mounting are dimensioned by a dashed line, which is screwed with three screws. The maximum cable cross-section for all device screw terminals is 2,5 mm².

Natural air circulation should be allowed inside the switchgear at the installation site and its immediate surroundings. Do not install other equipment that could be a significant source of heat near to the instrument.

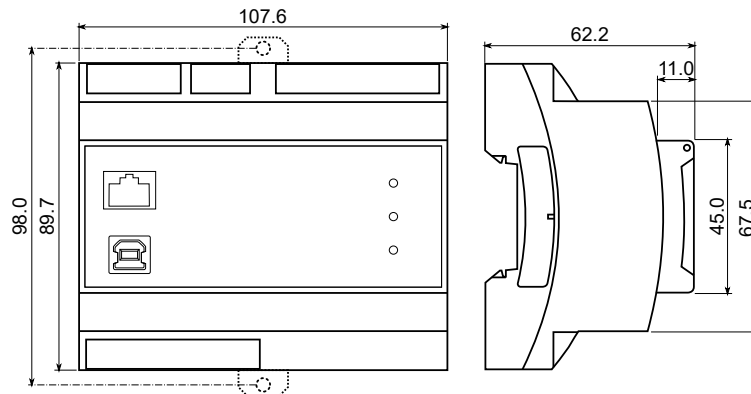

Figure 3: Dimensions of ARTIQ 244.

2.4.1 Auxiliary voltage

The instrument supply voltage must be connected to the terminals X1 and X2 via suitable fuses with appropriate characteristics for the respective environment (see diagram in figure 4 for power off). The disconnect must be located on the left side of the device within reach of the operator. The circuit breaker must be marked as a disconnect switch. A 1 A to 6 A circuit breaker is a suitable circuit breaker, but its location and function must be clearly identified (using the '0' and 'I' symbols according to EN 61010-1). The power supply galvanically separates the power terminals of the device from other internal circuits.

In addition to terminals X1 and X2, the input/output terminal block also contains a functional ground terminal E. This terminal is not important for the safety of the device (ARTIQ 244 is designed as a double

/ reinforced insulation device), but it affects the behavior of unconnected voltage inputs (measures zero voltage) and reduces the strain on insulating barriers in case of transient phenomena in the network, thus increasing durability and reliability of the instrument. In TN and TT networks, this terminal must be connected to a ground conductor (TN-S) or PEN conductor (TN-C). In the case of IT installation, it is not necessary to connect the terminal if it is desired to minimize the effect on network isolation.

Recommended type of conductor H07V-U (CY)
 Recommended minimum conductor cross-section: 0,75 mm²
 Maximum conductor cross section: 2,5 mm²

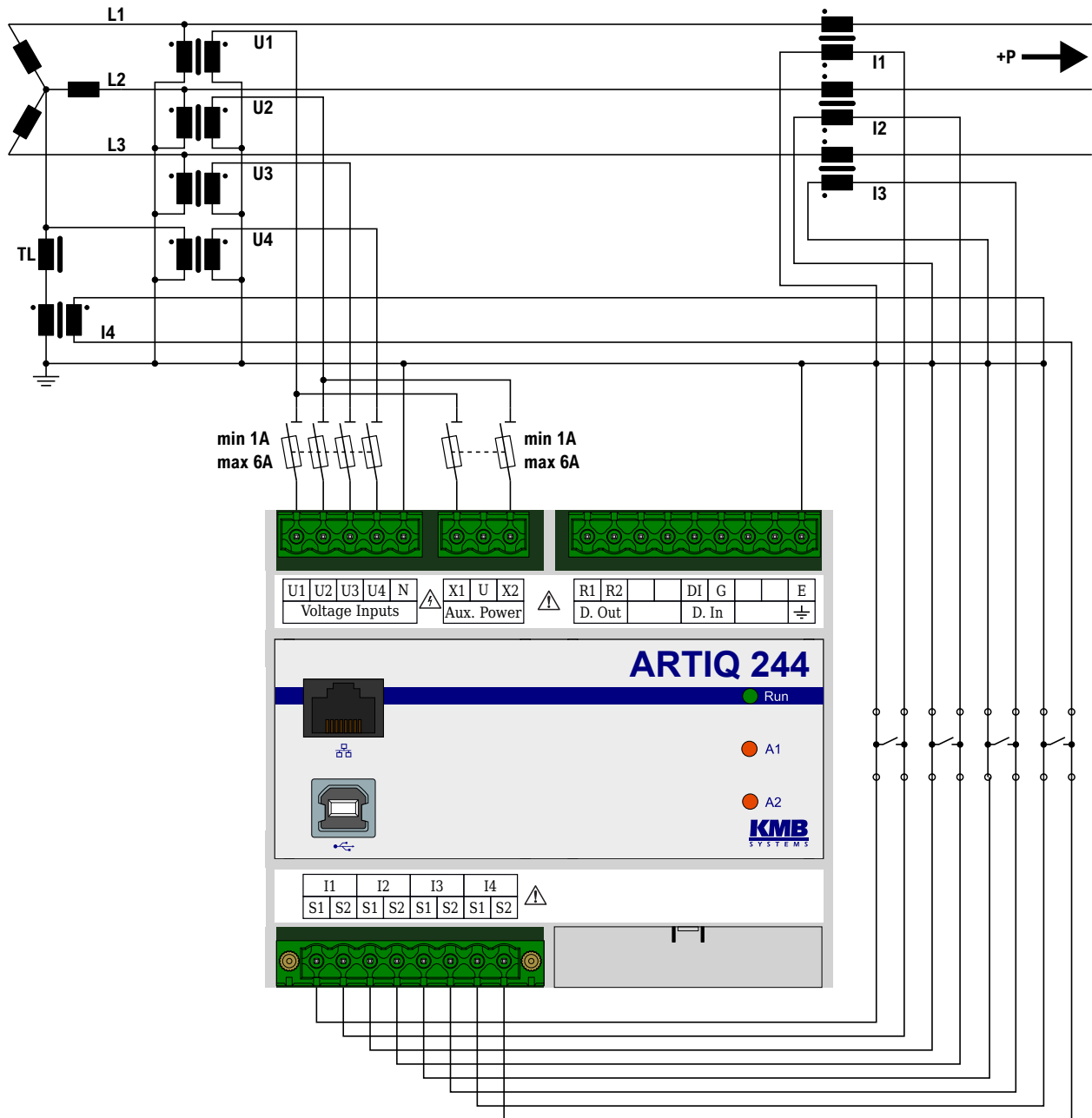

Figure 4: HV measurement using PTs and CTs. Power is supplied using line-to-line voltage from potential transformers.



The device as a whole is intended for measurement in networks of overvoltage category up to 300 V/CAT III.

2.4.2 Measured voltages

Overvoltage category signals 300 V/CAT III can be directly connected to the voltage measurement inputs.

The measured voltages are connected to terminals U1, U2, U3 and U4. The center conductor connection terminal is marked N — not connected in a delta or Aron's wiring. All voltage measuring inputs are connected to the internal circuits via high impedance.

Measured voltages should be protected, for example, by 1 A to 6 A fuse with a suitable tripping characteristic. Measured voltages can also be connected via instrument (measuring) voltage transformers, especially in MV and HV networks.

Recommended type of conductor	H07V-U (CY)
Recommended minimum conductor cross-section:	0,75 mm ²
Maximum conductor cross section:	2,5 mm ²

2.4.3 Measured currents

The instrument is designed for indirect current measurement via external current transformers (CTs). The CT orientation (terminals S1 and S2) must be observed during installation. Accuracy can be verified by knowing the current active energy transfer direction according to the sign of the respective active power or by the phasor diagram by using the ENVIS.Daq software.

Option „X/1A“ The secondary CT winding of nominal 1 A must be fed to the terminals S1 and S2 of the current inputs I1, I2, I3 and I4. In the figure 4, there is an example of a HV network. In MV/HV networks, it is always necessary to ground the S1 (or S2) terminals of all CTs at one point.

Recommended type of conductor:	H07V-U (CY)
Recommended minimum conductor cross-section:	2,5 mm ²
Maximum conductor cross section:	2,5 mm ²

CTP 4 X/1A Doplňit angličtinu

Recommended type of conductor:	H07V-U (CY)
Recommended minimum conductor cross-section:	2,5 mm ²
Maximum conductor cross section:	2,5 mm ²

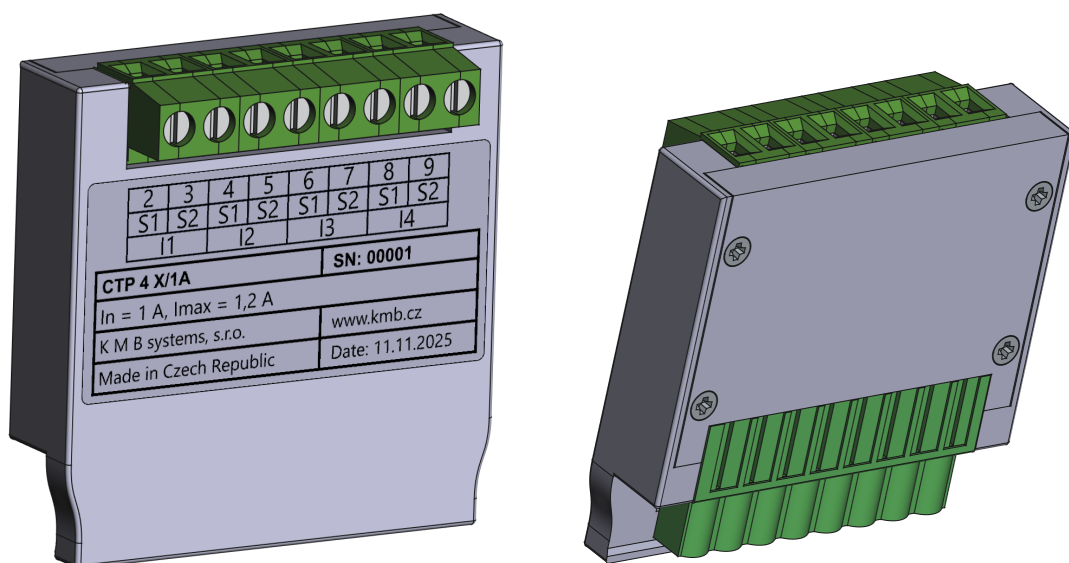

Figure 5: CTP 4 X/1A module for MTP protection.

2.4.4 Connection of communication channels

All the peripherals listed below are galvanically isolated from the rest of the device and from each other.

USB The USB communication interface is used for local parameterization of the instrument and easy and fast reading of the recorded data. The USB-B connector is located on the front panel of the machine. ARTIQ 244 is a USB 2.0 device.

Ethernet The 100Base-T Ethernet Interface Module with RJ-45 connector marked as ETH is located on the front panel of the instrument. The type and maximum length of the required cable must match IEEE 802.3.

2.4.5 Digital output

The device is equipped with one relay output on terminals R1 and R2. The output is galvanically isolated from all other circuits. The software of the device treats the relay as the DO1 output.

Recommended type of conductor	H05V-U (CY)
Recommended minimum conductor cross-section:	0,5 mm ²
Maximum conductor cross section:	2,5 mm ²

2.4.6 Digital input

The device is equipped with one digital input on terminals DI and G. Pulses of 7 to 30 V_{DC} can be connected to terminal DI from an external PPS (pulse per second) or PPM (pulse per minute) signal source for external synchronization of the real-time clock. This input is passive, galvanically isolated and bipolar — so the polarity of the connected signal does not matter. The software of the device treats the DI input as the DI2 input.

Recommended type of conductor	H05V-U (CY)
Recommended minimum conductor cross-section:	0,5 mm ²
Maximum conductor cross section:	2,5 mm ²

2.5 Description of LED indicators

Function of the red LED alarm diods *A1*, *A2* can be configured in the IO section of instrument configuration. The green *Run* LED is used to indicate the correct program run:

3 s on, 1 s off is a normal state of the instrument

0.2 s on, 0.2 s off indicates a special status of 10s after power up. Fast flashing can be used to visually check the device restart when the power supply is disconnected/connected, when a change of settings is required that requires a reboot or a firmware upgrade.

During the firmware upgrade, when the device is in the bootloader, all three LEDs flash together. The states are as follows:

Slow blinking means that instrument restarted and is now in bootloader.

Steady on for a few seconds indicates operations with the internal storage.

Fast blinking indicates uploading of the new firmware.

3 Technical parameters

3.1 Basic parameters

Auxiliary Voltage	
rated auxiliary voltage range	120 ÷ 240 V _{AC} 120 ÷ 250 V _{DC}
AC auxiliary voltage range, f: 40 ÷ 100 Hz	75 ÷ 275 V _{AC}
DC auxiliary voltage range	75 ÷ 300 V _{DC}
power consumption	8 VA / 3 W
overvoltage category	300 V CAT III
pollution degree	2
maximum operating altitude	2000 m
connection	isolated, polarity free

0000000000

Other Specifications	
operational temperature	- 25 to 60°C
storage temperature	- 30 to 80°C
operational and storage humidity	< 95 % - non-condensable environment
EMC – generic standards	EN 61326-1 ed. 3 EN 61000-6-2 ed. 4
EMC – immunity	EN 61000-4-2 ed. 2: level 2 (4 kV) air EN 61000-4-2 ed. 2: level 3 (8 kV) contact EN 61000-4-3 ed. 4: level 3 (10 V/m, 80 – 1000 MHz) EN 61000-4-3 ed. 4: level 2 (3 V/m, 1,4 – 6 GHz) EN 61000-4-4 ed. 3: level 3 (2 kV) measuring and power inputs EN 61000-4-4 ed. 3: level 3 (1 kV) inputs/outputs, communication EN 61000-4-5 ed. 3: level 3 (2/1 kV) measuring inputs EN 61000-4-5 ed. 3: level 2 (1 kV) communication EN 61000-4-6 ed. 4: level 3 (10 V, 0.15 – 80 MHz) EN 61000-4-19: level 4 (20/10 V, 4/2 A)
EMC – emissions	EN 55032 ed.2, level A EN 55011 ed. 4, level A EN 61000-3-2 ed. 5 EN 61000-3-3 ed. 3
safety	EN 61010-1 ed. 2 EN 61010-2-030 ed. 2
communication ports	USB, Fast Ethernet (100 Mbit)
communication protocols	KMB, Modbus TCP, WEB server, JSON, DHCP, SNTP
status indication	1 × green LED, 2 × red LED
sampling frequency 50 Hz (60 Hz)	28,8 kHz (28,8 kHz)
resolution of AD converter	24 bit
accuracy of RTC	+/- 0,2 second per day from 0°C to +40°C (+/- 2 ppm) +/- 0,3 second per day from -40°C to +85°C (+/- 3,5 ppm)
capacity of RTC backup battery	> 5 years (at room temperature, without supply voltage applied)
recommended calibration interval	24 to 36 months
ingress protection front panel whole instrument	IP 40 IP 20
protection class	II
service life	> 15 years
dimensions front panel whole instrument	108 x 45 mm 108 x 90 x 61 mm
weight	max. 0.3 kg

3.2 Measured quantities

Measured Quantities – Voltage	
Frequency	
f_{NOM} – nominal frequency	50 Hz
PLL capture range	$F_{\text{NOM}} = 50 \text{ Hz}: 40 \div 57,5 \text{ Hz}$
measuring range	$40 \div 57.5 \text{ Hz}$ (15 ÷ 510 Hz in “DC-500” mode)
uncertainty	$\pm 5 \text{ mHz}$
Voltage	
voltage input option	standard variant („100“)
U_{NOM} (U_{DIN})– rated voltage	57.7 / 100 V _{AC}
measuring range line-to-neutral	0.7 ÷ 190 V _{AC}
measuring range line-to-line	1 ÷ 329 V _{AC}
intrinsic uncertainty ($t_A=23\pm 2^\circ\text{C}$)	0.05 % of rdg + 0.01 % of rng
temperature drift	0.03 % of rdg + 0.01 % of rng / 10 °C
measurement category	300 V CAT III
permanent overload	1300 V _{AC} (UL–N)
peak overload, 1 second	1900 V _{AC} (UL–N)
burden power (impedance)	< 0.1 VA ($R_i = 2.8 \text{ M}\Omega$)
Voltage Unbalance	
measuring range	0 ÷ 10 %
measuring uncertainty	$\pm 0.15 \text{ %}$
THDU	
measuring range	0 ÷ 20 %
measuring uncertainty	$\pm 0.1 \text{ %}$
Harmonics up to 128th order	
reference conditions	other harmonics up to 200 % of class 3 acc. to IEC 61000–2-4 ed.2
measuring range	10 ÷ 200 % of class 3 acc. to IEC 61000–2-4 ed.2
measuring uncertainty	the levels of class I acc. to IEC 61000–4-7 ed.2

Mains Signaling Voltage (with optional firmware module „RCS“ only)	
measuring range	0 ÷ 20 % U_{NOM}
frequency range	100 ÷ 6000 Hz
measuring uncertainty	the levels of class I acc. to IEC 61000–4-7 ed.2

Measured Quantities – Current, Temperature	
Current	
current input option	X/1A
I_{NOM} (I _B) – rated (basic) current	1 A _{AC}
measuring range	0.0025 ÷ 10 A _{AC}
intrinsic uncertainty (t _A =23 ±2 °C)	0.10 % of rdg + 0.01 % of rng
temperature drift	0.03 % of rdg + 0.01 % of rng / 10 °C
measurement category	150 V CAT III
permanent overload	15 A _{AC}
peak overload 1 second, maximum repetition frequency > 5 minutes	70 A _{AC}
burden power (impedance)	< 1 VA (R _i < 10 mΩ)
Current Unbalance	
measuring range	0 ÷ 100 %
measuring uncertainty	± 0.15 %
Harmonics & Interharmonics up to 128th order	
reference conditions	other harmonics up to 1000 % of class 3 acc. to IEC 61000–2-4 ed.2
measuring range	500 % of class 3 acc. to IEC 61000–2-4 ed.2
measuring uncertainty	I _h ≤ 10 % I _{NOM} : ± 0.1 % I _{NOM}
	I _h > 10 % I _{NOM} : ± 0.5 % of rdg
THDI	
measuring range	0 ÷ 200 %
measuring uncertainty	THDI ≤ 100 %: ± 0.1 %
	THDI > 100 %: ± 0.1 % of rdg
Temperature (input for external Pt100 RTD)	
measuring range	- 50 ÷ 170°C
measuring uncertainty	± 1 °C (three-wire connection)
Temperature (internal sensor, measured value affected by the instrument power dissipation)	
measuring range	- 40 ÷ 85°C
measuring uncertainty	± 3 °C

www.ohmtron.com

Measured Quantities – Power, Power Factor, Energy	
Active / Reactive Power, Power Factor (PF), cos φ (P_{NOM} = U_{NOM} x I_{NOM})	
reference conditions "A": ambient temperature (t _A) U, I for active power, PF, cos φ for reactive power	23 ± 2 °C U = 80 ÷ 120 % U _{NOM} , I = 1 ÷ 120 % I _{NOM} PF = 1.00 PF = 0.00
act. / react. power uncertainty	± 0.1 % of rdg ± 0.005 % P _{NOM}
PF & cos φ uncertainty	± 0.005
reference conditions "B": ambient temperature (t _A) U, I for active power, PF, cos φ for reactive power	23 ± 2 °C U = 80 ÷ 120 % U _{NOM} , I = 2 ÷ 120 % I _{NOM} PF ≥ 0.5 PF ≤ 0.87
act. / react. power uncertainty	± 0.2 % of rdg ± 0.005 % P _{NOM}
PF & cos φ uncertainty	± 0.005
temperature drift of powers	± 0.05 % of rdg ± 0.02 % P _{NOM} / 10 °C
Energy	
measuring range	corresponds to U & I measuring ranges 4 quadrant energy counters for both active and reactive energies
active energy uncertainty	class 0.2S acc. to EN 62053 – 22
reactive energy uncertainty	class 0.5S acc. to EN 62053 – 24

3.3 Inputs and outputs

Digital Outputs & Digital Inputs: 1 output, 1 input	
Digital Relay Output	
type	N.O. contact
load rating	250 V _{AC} / 30 V _{DC} , 3 A
Digital Input for RTC synchronization	
type	Optically isolated, bipolar, internal
maximum voltage	30 V _{DC}
voltage for "logical 1"	> 7 V _{DC}
voltage for "logical 0"	< 3 V _{DC}
input current	5 mA @ 12V / 13 mA @ 24V
dynamic par. (pulse counter): - pulse/gap duration - maximum frequency	≥ 0.5 / 0.5 ms 1 kHz

3.4 Power quality and energy management

Table 3: IEC 61000-4-30, 61000-4-15, 61000-4-7

Function characteristics according to IEC 61000-4-30 ed. 3				
Function	Class	Uncertainty	Measuring range	Notes
frequency	A	± 10 mHz	40 ÷ 70 Hz	
magnitude of the supply	A	± 0.1 % U _{din}	10 ÷ 200 % U _{din}	
flicker	A	± 5 % of value or $\pm 0,05$	0.2 ÷ 20	2, 4)
dips and swells	A	± 0.1 % U _{din} , ± 1 cycle	5 ÷ 200 % U _{din}	2)
interruptions	A	± 1 cycle	unlimited	2)
unbalance	A	± 0.15 %	0.5 ÷ 10 %	
voltage harmonics & interharmonics 50 Hz (60 Hz)	A	the levels of class I acc. IEC 61000-4-7 ed.2	10÷200 % of cl. 3, 128(108) h acc. IEC 61000-2-4 ed.2	1)
mains signaling voltage	A	the levels of class I acc. IEC 61000-4-7 ed.2	0 ÷ 20 % U _{din} Fmsv: 100 ÷ 3000 Hz	1, 3)

1) ... according to IEC 61000-4-7 ed. 2

2) ... with optional firmware module „PQ A“

3) ... with optional firmware module „RCS“

4) ... class F1 according to IEC 61000-4-15 ed. 2

Table 4: EN 50160

Power Quality acc. to EN 50160 (with optional firmware module „PQ A“ only)	
evaluation period	weekly
Interharmonics up to 128th order (108th order @ 60 Hz)	
reference conditions	other harmonics up to 200 % of class 3 acc. to IEC 61000–2-4 ed.2
measuring range	10 ÷ 100 % of class 3 acc. to IEC 61000–2-4 ed.2
measuring uncertainty	the levels of class I acc. to IEC 61000–4-7 ed.2
Flicker (with optional firmware module „PQ A“ only)	
class	F1 acc. to IEC 61000–4-15 ed. 2
measuring uncertainty	± 5 % of rdg
measuring range	0.2 ÷ 10
Voltage Dips & Swells (with optional firmware module „PQ A“ only)	
measuring uncertainty	+/- 0.1 % of rng
Voltage Interruptions (with optional firmware module „PQ A“ only)	
measuring uncertainty	+/- 0.1 % of rng
duration measuring uncertainty	± 1 cycle
Mains Signaling Voltage	
evaluation period	3s interval

Table 5: IEC 61557-12: Equipment for measuring and monitoring electrical parameters

Instrument characteristics according to IEC 61557-12	
power quality assessment function	PQI-A
classification according to par. 4.3	
direct voltage connection	SD
voltage connection via VT	SS
temperature according to par. 4.5.2.2	K55
humidity + altitude according to par. 4.5.2.3	< 95 % - noncondensation conditions < 2000 m
active power/energy function performance class	0.2

Function characteristics according to IEC 61557-12				
Model „X/1A“, $I_{NOM} = 1\text{ A}$, $U_{NOM} = 100\text{ V}$				
Symbol	Function	Class	Measuring range	Notes
P	total effective power	0.5	0 ÷ 5.7 kW	
QA, QV	total reactive power	0.5	0 ÷ 5.7 kvar	
SA, SV	total apparent power	0.5	0 ÷ 5.7 kVA	
Ea	total active energy	0.5	0 ÷ 5.7 kWh	
ErA, ErV	total reactive energy	0.5	0 ÷ 5.7 kvarh	
EapA, EapV	total apparent energy	0.5	0 ÷ 5.7 kVAh	
f	frequency	0.02	40 ÷ 57.5 Hz	
I	phase current	0.2	0.1 ÷ 10 AAC	
IN	neutral current measured	0.2	0.1 ÷ 30 AAC	
INc	neutral current calculated	–	–	
V	line-to-neutral voltage	0.1	9.5 ÷ 190 VAC	
U	line-to-line voltage	0.1	16 ÷ 329 VAC	
PFA, PFV	power factor	0.5	0 ÷ 1	
Pst, Pit	flicker	5	0.4 ÷ 10	2)
Vdip	voltage dips	0.5	9.5 ÷ 57.5 VAC	2)
Vswl	voltage swells	0.5	57.5 ÷ 190 VAC	2)
Vtr	transients overvoltage	–	–	
Vint	voltage interruption	0.5	0 ÷ 9.5 VAC	2)
Vnba	voltage unbalance (amp.)	0.2	0 ÷ 10 %	
Vnb	voltage unbalance (ph. & amp.)	0.2	0 ÷ 10 %	
Vh	voltage harmonics 50 Hz (60 Hz)	1	up to 128 th (108 th) order	1)
THDv	voltage total harmonic distortion (rel. to fund.)	1	0 ÷ 20 %	1)
THD-Rv	voltage total harmonic distortion (rel. to RMS)	1	0 ÷ 20 %	1)
Ih	current harmonics 50 Hz (60 Hz)	2	up to 128 th (108 th) order	1)
THDi	current total harmonic distortion (rel. to fund.)	2	0 ÷ 200 %	1)
THD-Ri	current total harmonic distortion (rel. to RMS)	2	0 ÷ 200 %	1)

1) ... according to IEC 61000-4-7

2) ... with optional firmware module „PQ A“

4 Maintenance, service and warranty

Maintenance The Network Analyzer and meter ARTIQ 244 does not require any special maintenance. For reliable operation, it is only necessary to adhere to the specified operating conditions and not to expose it to rough handling and exposure to water or various chemicals that could cause damage. It is advisable to clean the product regularly (preferably during a preventive inspection of the entire system) in the switched off state with a dry cloth or brush so that the ventilation openings and clamps remain clean. The lithium battery installed in the instrument is capable of backing up memory and RTC for approximately 5 years without a power supply at an average temperature of 20°C and a typical load current in the instrument ($< 10 \mu A$). If the battery is discharged, it is necessary to send the instrument to the manufacturer for battery replacement.

Service In case of product failure, a warranty must be claimed with the manufacturer at:

K M B systems, s.r.o.
Dr. Milady Horakove 559
Liberec VII-Horni Ruzodol
460 07 Liberec
Czech republic
Tel.: +420 485 130 314
E-mail: kmb@kmb.cz
Web: www.kmbsystems.com

The product must be properly packed to avoid shipping damage. A description of the fault must be provided with the product.

If warranty repair is claimed, the warranty card must also be sent. If an out-of-warranty repair is required, an order for this repair must be attached.

Warranty card: The device is warranted for a period of 24 months from the date of purchase, but no longer than 30 months from the manufacturer's delivery date. Defects that arise within these time limits demonstrably due to defective design, faulty construction or unsuitable material will be repaired free of charge by the manufacturer or authorized service organization.

The warranty also expires during the warranty period if the user performs unauthorized modifications or changes on the device, if the device connects to incorrectly selected values, if the device has been violated by unauthorized falls or improper handling, or if it has been operated in contrary to the specified technical parameters.

Product type:	Serial number:
Delivery date:	Checkout control:
		Manufacturer's stamp:
Date of sale:	Seller's stamp:

T A
C R

This project is co-financed from the state budget by the Technology Agency of the Czech Republic within the THETA Programme.

www.tacr.cz/en



K M B systems, s. r. o.
Dr. Milady Horákové 559
Liberec VII - Horní Růžodol
460 07 Liberec, Czech Republic

Tel.: +420 485 130 314
E-mail: kmb@kmb.cz
Web: www.kmb.cz